

Intellectual Property and the Arts

June 29, 2012

The Art Institute of Phoenix

Tom Galvani

Registered U.S. Patent Attorney

Thomas W. Galvani, P.C.

www.galvanilegal.com

Intellectual Property and the Arts

Issues that arise in the arts:

- Patents
- Trade Secrets
- Copyright
- Trademarks / Trade Dress
- Contracts

Intellectual Property and the Arts

Issues that arise in the arts:

- Patents
- Trade Secrets
- Copyright
- Trademarks / Trade Dress
- Contracts



Exclusive rights
against the world

Intellectual Property and the Arts

Issues that arise in the arts:

- Patents
- Trade Secrets
- Copyright
- Trademarks / Trade Dress
- Contracts

Exclusive rights
against the world



Exclusive rights against
the contracting party



Patents

- Patent protection is available only by applying to the US Patent and Trademark Office.
- Protection for 14-20 years
- Two main types:
 - Utility Patents – protect the structural and functional aspects of functional items & inventions
 - Design Patents – protect the ornamental aspects of functional items & inventions

Utility Patents - Examples

U.S. Patent Jan. 10, 2012 Sheet 1 of 14 US 8,094,167 B2

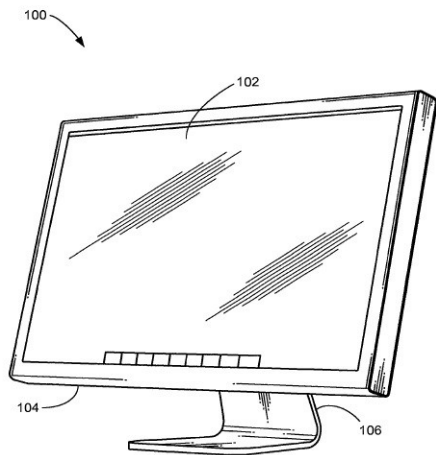

FIG. 1

U.S. Patent Jan. 10, 2012 Sheet 2 of 14 US 8,094,167 B2

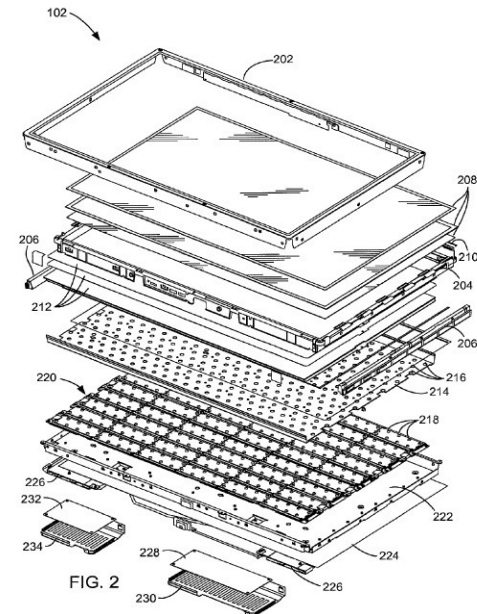

FIG. 2

Utility Patents - Examples

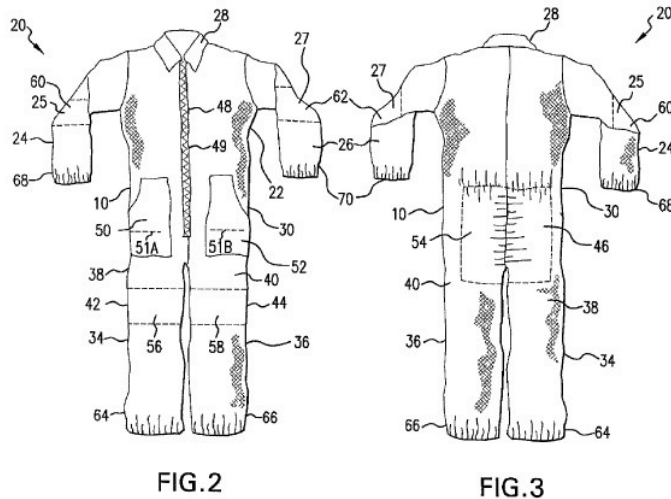

FIG. 2

FIG. 3

U.S. Patent

Jul. 5, 2011

Sheet 2 of 2

US 7,971,283 B2

“Non-Woven, Flame-Resistant Coveralls”

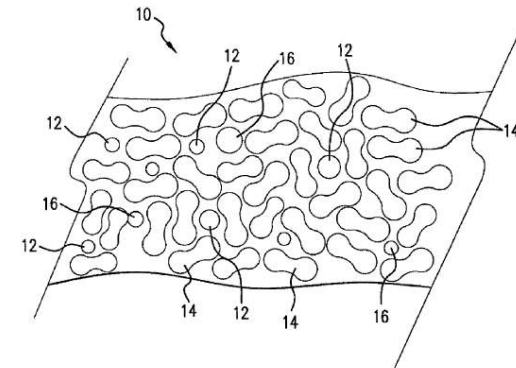

FIG. 1

U.S. Patent

Jul. 5, 2011

Sheet 1 of 2

US 7,971,283 B2

Design Patents - Examples



US000564224S

(12) **United States Design Patent** (10) Patent No.: **US D564,224 S**
 Giannini (45) Date of Patent: **Mar. 18, 2008**

(54) **HANDBAG**

(75) Inventor: **Frida Giannini**, Florence (IT)

(73) Assignee: **Gucci America, Inc.**, New York, NY (US)

(**) Term: **14 Years**

(21) Appl. No.: **29/279,018**

(22) Filed: **Apr. 17, 2007**

(51) **LOC (8) CL.** **03-01**

(52) **U.S. Cl.** **D3/243**

(58) **Field of Classification Search** **D3/231, D3/234, 235, 237, 238, 239, 240, 241, 242, D3/243, 244, 245, 246, 303, 318; 150/100, 150/107, 108, 110, 112, 113, 114, 118, 120, 190/100, 106, 108, 109, 110, 111, 112, 115, 190/118, 121, 122, 903, 383/6, 7, 8, 10, 383/12, 16, 30, 31, 38, 42, 66, 78, 84, 93, 383/97, 98, 117, 120, 907**

See application file for complete search history.

(56) **References Cited**

U.S. PATENT DOCUMENTS

132,412 A *	10/1872	Reed	150/112
D15,744 S *	1/1885	Rice	D3/235
2,727,448 A *	12/1955	Kadan	150/107
D309,660 S *	9/2005	Hanley	D3/246
D532,969 S *	12/2006	Fendi	D3/243
D544,204 S *	6/2007	Gonzalez	D3/246

OTHER PUBLICATIONS

Gucci advertisement, InStyle magazine, Apr. 2007.

1 Claim, 5 Drawing Sheets

Web page from Saks Fifth Avenue web site, <http://www.saksfifthavenue.com/main/ProductDetail.jsp?PRODUCT%3C%3Eprod_id=845524446154324&Goto=product&site_refer=360SSPPLP&kw_refer=Gucci+Indy+Medium+Top+Handle+Bag&sitechengiao=55&isproduct=Gucci+Indy+Medium+Top+Handle+Bags>, Mar. 22, 2007.

Web page from Gucci web site, <http://www.gucci.com/us/english/us/fall-winter-07/handbags>, Oct. 9, 2007.

Web page from Gucci web site, <http://www.gucci.com/us/templates/print.html>, Oct. 9, 2007.

* cited by examiner

Primary Examiner—Gary D. Watson
Assistant Examiner—Monica A Weingart
 (74) *Attorney, Agent, or Firm*—Arnold & Porter LLP

(57) **CLAIM**

The ornamental design for a handbag, as shown and described.

DESCRIPTION

FIG. 1 is a top left perspective view of a handbag showing my new design;

FIG. 2 is a front view thereof;

FIG. 3 is a rear view thereof;

FIG. 4 is a left side view thereof, the right side being a mirror image of the left side;

FIG. 5 is a top view thereof; and,

FIG. 6 is a bottom view thereof.

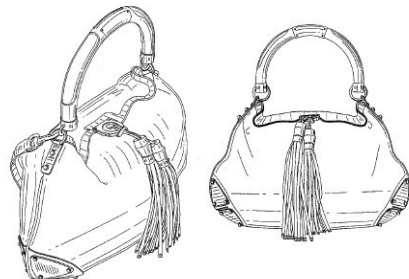

U.S. Patent Mar. 18, 2008 Sheet 1 of 5 US D564,224 S

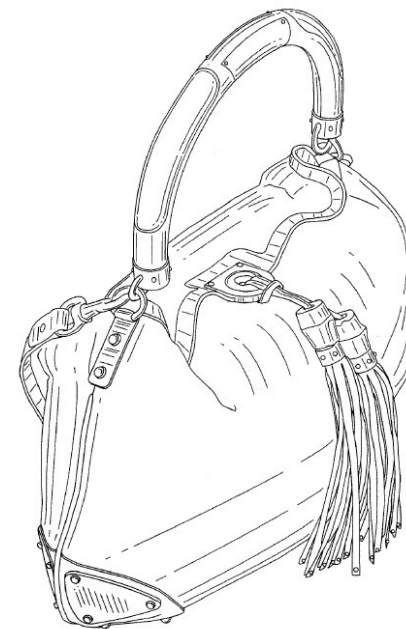

FIG. 1

Design Patents - Examples

U.S. Patent

Sep. 28, 1999

Sheet 1 of 12

Des. 414,424

Fig. 1

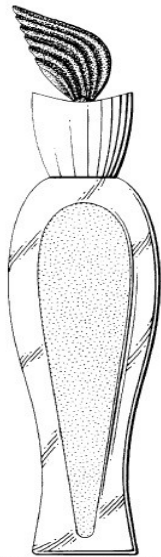

©1997 PARFUMS GIVENCHY, INC.

Fig. 2

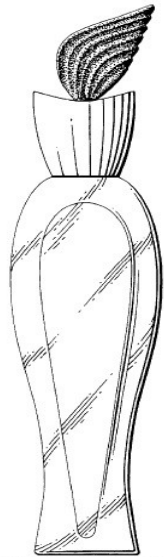

©1997 PARFUMS GIVENCHY, INC.

March 1, 1938.

S. FERRAGAMO
SHOE OF SIMILAR ARTICLE
Filed Jan. 20, 1938

Des. 108,619

Fig. 1

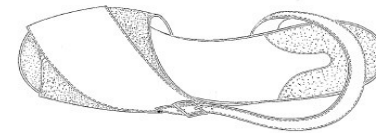
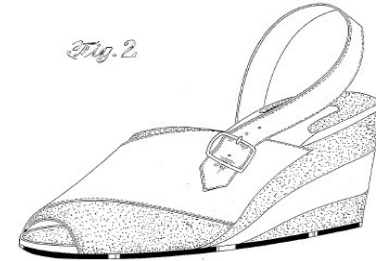



Fig. 2



BY *Salvatore Ferragamo* INVENTOR
Carl W. Oken ATTORNEY.

Design Patents - Examples



US000413105S

United States Patent [19] [11] **Patent Number: Des. 413,105**

Jobs et al. [45] **Date of Patent: Aug. 24, 1999**

[54] **COMPUTER ENCLOSURE**

[75] Inventors: **Steven P. Jobs, Palo Alto; Jonathan P. Ive, Daniel J. Coster, both of San Francisco; Christopher J. Stringer, Francisco; Daniele De Iulio, San Francisco; Bart K. Andre, Menlo Park; Richard P. Howarth, San Francisco; Calvin Q. Seid, Palo Alto; Douglas B. Satzger, San Carlos; Marc J. van de Loo, Palo Alto, all of Calif.**

[73] Assignee: **Apple Computer, Inc., Cupertino, Calif.**

[**] Term: **14 Years**

[21] Appl. No.: **29,087,642**

[22] Filed: **May 6, 1998**

[51] LOC (6) CL: **14-02**

[52] U.S. CL: **D14/100; D14/113**

[58] **Field of Search** D14/100, 113, D14/114, 126, 102, 105, 125, 106, 345/133, 156, 901-5, 388/180, 184, 325, 739, 248/917-24

[56] **References Cited**

U.S. PATENT DOCUMENTS

D. 314,373	2/1991	Sachernan	D14/113
------------	--------	-----------	---------

1 Claim, 8 Drawing Sheets

CLAIM

The ornamental design for a computer enclosure, as shown and described.

[57] **DESCRIPTION**

FIG. 1 is a front, top, right side perspective view of a computer enclosure, showing our new design;

FIG. 2 is a front view thereof;

FIG. 3 is a right side view thereof;

FIG. 4 is a rear view thereof;

FIG. 5 is a left side view thereof;

FIG. 6 is a top view thereof;

FIG. 7 is a bottom view thereof; and,

FIG. 8 is a right side view of a computer enclosure with a flip stand extended, showing our new design.

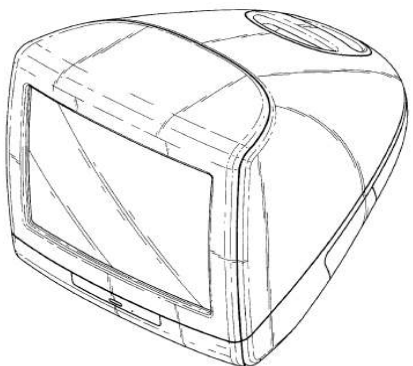

United States Patent [19] [11] **Patent Number: Des. 281,686**

Rivette et al. [45] **Date of Patent: Dec. 10, 1985**

[54] **TELEPHONE**

[75] Inventors: **Denni F. Rivette, Chicago; Harry Diako, South Barrington, both of Ill.**

[73] Assignee: **Marvin Glass & Associates, Chicago, Ill.**

[**] Term: **14 Years**

[21] Appl. No.: **444,601**

[22] Filed: **Nov. 26, 1982**

[52] U.S. CL: **D14/53; D14/63; D14/64; 179/179**

[58] **Field of Search** D14/19.31, 69, 53, 60, D14/57, 63, 62, D24/38, D9/328, 420, D3/75; D6/167; 179/103, 100 R, 179, D21/155; D27/40, 41; D7/5

[56] **References Cited**

U.S. PATENT DOCUMENTS

D. 59,438	10/1921	Stoek	D9/329
D. 115,837	7/1939	Petrolid	D9/420
D. 161,898	2/1951	Blod et al.	D9/420
D. 201,443	6/1965	Natali	D14/57
D. 207,491	4/1967	Zavano et al.	D14/53
D. 247,740	4/1978	Brady	D10/6
D. 258,734	3/1981	Lench	D14/17
D. 262,355	12/1981	Murewski	D14/53
D. 276,520	11/1984	Breslow et al.	D14/63
3,551,607	12/1967	Tommasi et al.	179/103
4,018,998	4/1977	Wegner	179/103

FOREIGN PATENT DOCUMENTS

1212389	11/1970	United Kingdom	179/103
---------	---------	----------------	---------

OTHER PUBLICATIONS

Giftware Business, Aug. 1982, p. 47; Pac Man-American Tele-Communication Corp. Pushbutton Phone.

"GTE Flip-Phone Telephone"; Rafter article in GTE Automatic Electric Journal, vol. 16, 11-1978, p. 216.

Representation of an apple with a bite cut out, in Apple Computer Inc. Booklet ©1980, showing bitten apple as a trademark on computer units.

Representation of Apple in U.S. Trademark Reg. No. 1,130,288, Apple Computer Inc., claiming use on Computers etc., since Jan. 1977.

Handbook of Designs and Devices, by A. D. F. Hamlin ©1923, p. plate 4, Item 28 (Sector Combinations).

Primary Examiner—Wallace R. Burke
Assistant Examiner—Horace B. Fay
Attorney, Agent, or Firm—John S. Paccoca

CLAIM

The ornamental design for a telephone, as shown and described.

DESCRIPTION

FIG. 1 is a top, side and front perspective view of a closed telephone showing our new design;

FIG. 2 is a perspective view of the telephone open;

FIG. 3 is an elevational view of the side of the closed telephone shown in FIG. 1, the opposite side being a mirror image;

FIGS. 4-7 are, respectively, front elevational, top plan, bottom plan, and rear elevational views of the closed telephone;

FIG. 8 is a top plan view of the open telephone;

FIG. 9 is an elevational view of the side of the open telephone shown in FIG. 2, the opposite side being a mirror image;

FIG. 10 is a front elevational view of the open telephone;

FIG. 11 is a top, side and front perspective view of a second embodiment thereof;

FIG. 12 is an elevational view of the side of the second embodiment, the opposite side being a mirror image;

FIG. 13 is a front elevational view thereof; and

The top and bottom plan, and the rear elevational views of the second embodiment are as shown in FIGS. 5, 6 and 7.

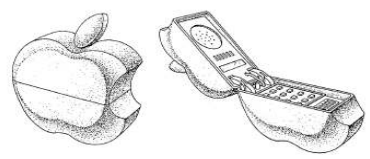

Trade Secrets

- Patent rights expire after 20 years
- Trade secrets continue forever, as long as they are truly kept secret, through:
 - Contracts
 - Privacy Policies
 - Safekeeping
- Recipes for foods, sauces, drinks, etc. are often kept as trade secrets

Copyright

- Protection for original works of authorship fixed in any tangible means of expression
- Exists upon creation; use form: © Year Name
- Formalized through registration with the Copyright Office
- Protection lasts for:
 - Life of the author + 70 years *or*
 - 95 or 120 years, for corporate works

Copyright

- Copyright protection is available for:
 - Literary works: books, articles, blog posts
 - Musical works: songs, albums, recordings
 - Pictorial, graphical, sculptural works: paintings, posters, toys, sculptures, casts, photographs
 - Architectural works: buildings, plans
- Copyright protection is not available for:
 - Clothing
 - Ideas
 - Slogans, Brand Names

Trademark / Trade Dress

- Indicates the source of a product or service
- May be words, symbols, ... almost anything
- Intended to prevent confusion
- Protection arises only with use of the trademark or trade dress
- TM v. ®

Trademark

- Word, phrase, symbol, logo, design, sound, etc. that identifies and distinguishes the source of a product from that of another

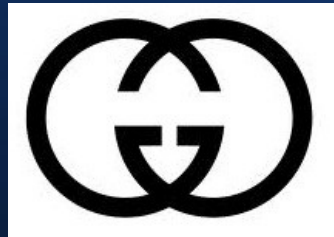

NIKE



Microsoft

Polo Ralph Lauren

Trade Dress

- Packaging, color, design, appearance, etc. that identifies and distinguishes the source of a product from that of another

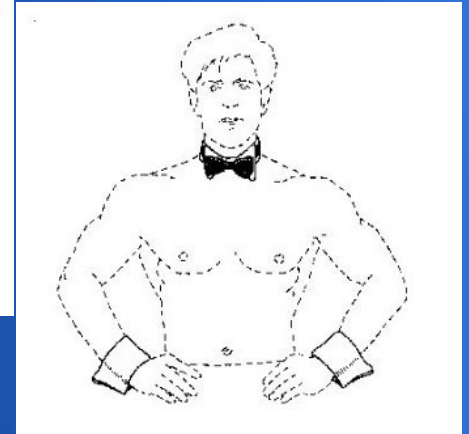
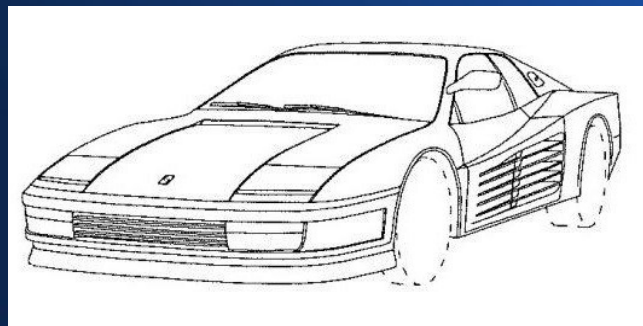
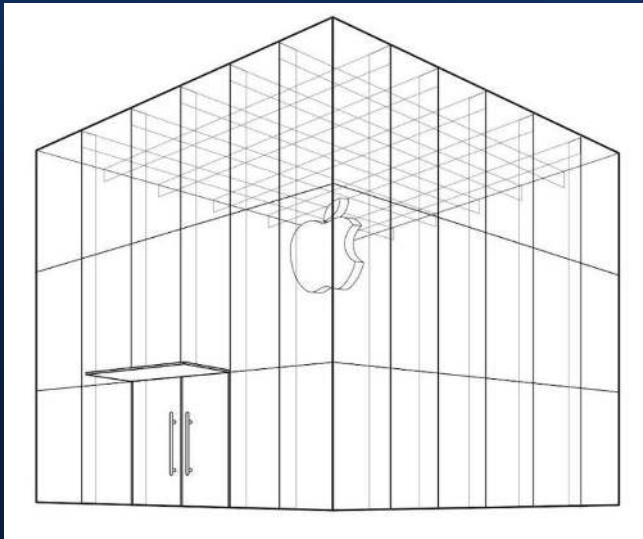

Trademark / Trade Dress Protection

To prevent a likelihood of confusion:

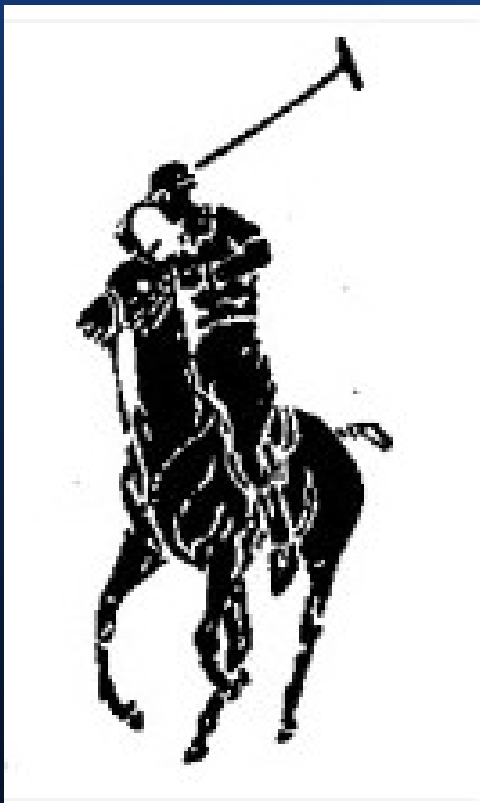

Trademark / Trade Dress Protection

To prevent a likelihood of confusion:



Contracts

- Non-Disclosure Agreements
- Non-Compete Agreements
- Copyright Ownership / Work Made for Hire Agreements
- Assignment Agreements

Questions

Tom Galvani

602-281-6481

tom@galvanilegal.com

www.galvanilegal.com